

# FREE TV AUSTRALIA OPERATIONAL PRACTICE OP-71

Recommended Settings of DVB-T Transmitter/Modulator's Operating Parameters and Transport Stream SI for Use in Temporary Events or in TV distribution Systems

Issue 1  
December 2014  
Page 1 of 14

---

## 1 SCOPE

This Operational Practice provides advice and recommendations for the setting-up of commercial grade DVB-T transmitter/modulators for use in MATV distribution systems, or where permitted, a DVB-T terrestrial broadcast transmitter to be temporarily operated at low power at special events. Such units may include multiple program inputs, Standard and/or High Definition video MPEG-2 or MPEG-4 (H.264) encoding. The unit should also include a capacity to generate System Information signalling, multiplex (MUX) the various streams together and have a COFDM DVB-T modulator with an RF output.

A simplified overview of the processes is included to give some understanding of the choices for setting modulation parameters and MPEG Transport Stream System Information so that an additional temporary transmission might operate compatibly in the presence of Australian free-to-air television signals and minimise RF interference or Service Information collisions with existing services.

The digital formats and DVB-T transmission offers many operating choices. While such setup information is distributed in many standards documents, this Operational Practice aims to provide reasons for and best choice recommendations for use in Australian setups.

At the rear of this document the reader will find the following summaries:

Annex A – Summary of Recommended Settings.

Annex B – Resulting bit-rate capacity for various modulator settings,

Annex C – lists Australian RF Channel frequencies.

## 2 BACKGROUND

All free-to-air television networks in Australia now terrestrially broadcast their programs using DVB-T COFDM RF transmissions and DVB-T capable TV receivers are now commonplace.

Consequently where additional programs are to be distributed in a local environment, RF transmissions in the DVB-T format may provide a better option over the formerly used analog PAL format that could only carry standard definition (SD) program content.

This applies to either Master Antenna closed cabled systems (MATV) and in-house systems, or for special events, where a temporary terrestrial broadcast transmission over a limited range might be permitted by means of an ACMA transmitter licence.

In both cases, these added DVB-T signals will usually need to operate in spectrum where Australian free-to-air (FTA) broadcasts are the licensed services.

Interference to reception of FTA services must be avoided. Interference could be caused by incorrect choice of the operating RF channels in an MATV system or generation of spurious signals typically by poor output filtering or amplifier overload. Also, receivers may react in unexpected ways if conflicting or wrong advisory digital control information is present in the added transmissions.

Detailed information may be obtained in the documents listed in the reference section of this Operational Practice.

## 3 DETERMINING SETUP PARAMETERS

The following is a list of parameters that generally need to be pre-determined in setting up a service and minimising the possibility of interference to other services.

### 3.1 Basic RF Choices

- Operating RF Channel Frequency (see Annex C)
- RF Channel Bandwidth (– in Australia 7MHz)
- Output RF level; Power transmitted at 'Special Events'

### 3.2 Basic Program Requirements

- Type of program(s) to be carried
- – Standard or High Definition and audio format
- - Aspect Ratio (Normally wide screen 16:9 but could be 4:3)
- Video Encoding – MPEG-2 or MPEG-4 (H.264) for video
- Audio Encoding – MPEG-1, AAC or AC-3 for audio.
- Digital bit-rate – for each program and total to be transmitted

### 3.3 DVB-T Parameters

- COFDM parameter operating choices (see Annex B)

### 3.4 Digital System Setup

- Assignment of data packet IDs (PIDs) if not assigned automatically.
- MPEG Transport Stream (TS) added information, including:
  - Service Name(s)
  - Service Provider
  - Original Network ID
  - Transport Stream ID
  - Program Service(s) – Name and ID
  - Program Logical Channel Number (LCN)
  - Tables to be avoided e.g.
    - -Time and Date tables (if TDT and TOT provided)
    - - EIT table (program guide)

#### 4 SIMPLIFIED SEPARATION OF FUNCTIONS

The overall function of providing a compatible DVB-T signal requires several stages or processes

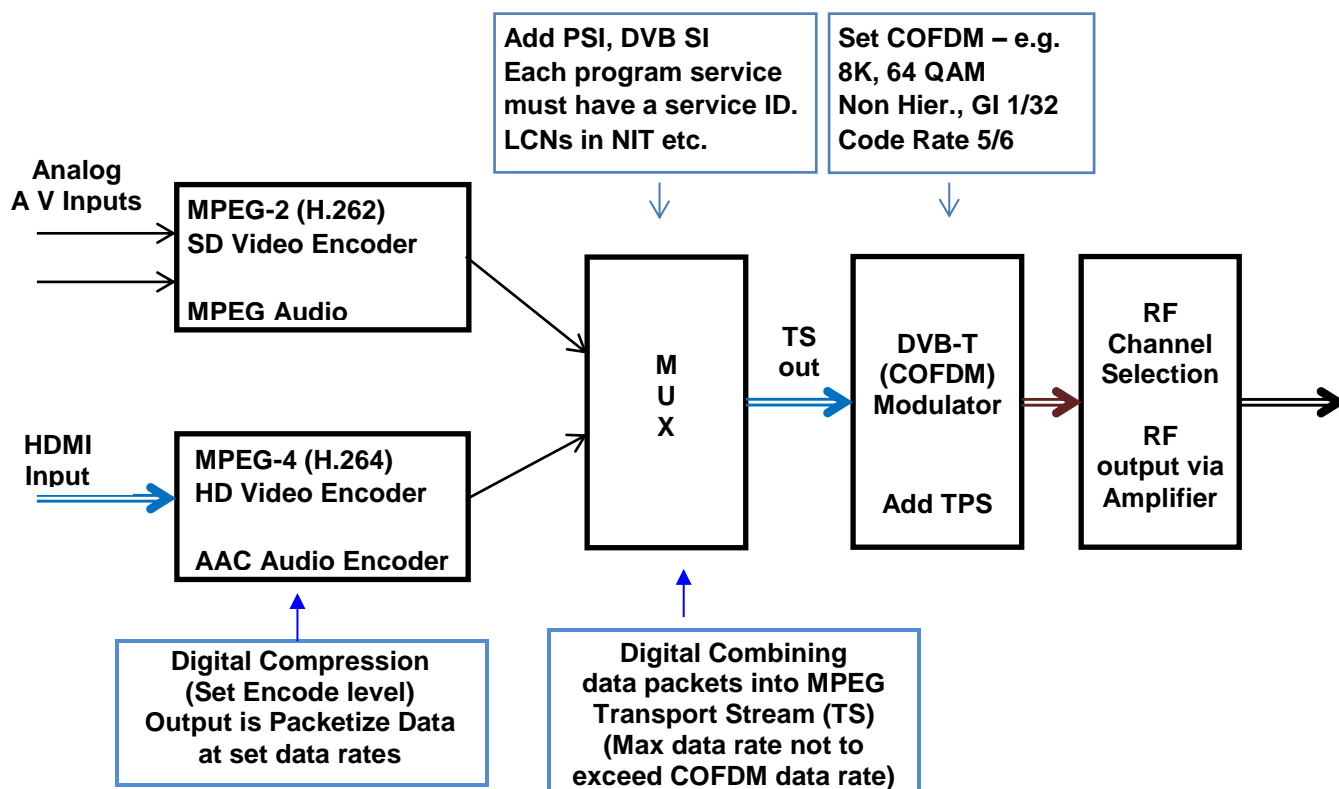

**Figure 1: Processes in a Typical All-in-one Modulator Unit**

#### 5 CHOICE OF TRANSMISSION CHANNEL FREQUENCIES AND OUTPUT POWER

##### 5.1 Channel Choice for the Broadcasting Services Band for Special One-Off Events

The transmission of DVB-T services in the broadcasting services bands for special events must be approved by the Australian Communications and Media Authority ([www.acma.gov.au](http://www.acma.gov.au)).

The licensed RF channel and permitted coverage area of the temporary service must be in accordance with the authorised power level defined in the temporary licence. The licensed operating RF channel frequency will be allocated with due regard to minimise interference to other nearby broadcast channels in use and is likely to be between Channel 28 and 51. There will be a requirement for RF filtering to minimise out-of-channel spurious levels.

The coverage area may be controlled by a combination of adjustment of the DVB-T modulation parameters and the radiated power (ERP) determined by the transmit antenna's radiation pattern and the unit's output power, augmented with a separate power amplifier (PA) if authorised. For a given power, the range of DVB-T modulation parameters enables

## **FREE TV AUSTRALIA OPERATIONAL PRACTICE OP-71**

Recommended Settings of DVB-T Transmitter/Modulator's Operating Parameters and Transport Stream SI for Use in Temporary Events or in TV distribution Systems

Issue 1  
December 2014  
Page 4 of 14

---

either an increased bit rate capacity at the expense of reduced reception quality (ruggedness), or vice-versa – see Annex B.

For example if only a single program is to be carried: an SD picture encoded with MPEG-2 or a HDTV picture encoded in MPEG-4 (H.264) would only require a total bit rate below 7Mbit/sec. This could be carried on a QPSK carrier at 1/10 the power of a 64QAM signal.

The total bit rate required depends whether a single or multiple programs are to be carried and whether MPEG-2 or the more efficient MPEG-4 (H.264) encoding is used..

### **5.2 Channel Choice for MATV or In-House Systems**

It is assumed that in a well-designed system the usable spectrum is not affected by unintentional ingress of external signals.

In choosing a suitable RF channel for a local signal modulator, the following should be noted:

- a) Annex C gives a list of 7 MHz channel allocations that all Australian DTV receivers should be able to tune to.
- b) In-house or MATV systems normally carry the off-air received local TV network signals, most usually on their received RF channels – i.e. in the range Ch6 to Ch12 and/or Ch28 to Ch51. In some cases, the off-air reception might be from a nearby re-transmitter/translator (gap-filler) site operating on different channels. The actual channels in use on the system should be checked.
- c) While the spectrum covered by channels 52 to 69 is now used by external mobile telecommunications, there may be no interference from external units operating in this band, so these channels could be suitable candidates.
- d) It is recommended to avoid interference to the licensed services the output of the temporary head end is well filtered and operating at least 2 channels (14 MHz) from any other licensed channels operating over-the-air in the area.

## **6 CHOICE OF ENCODING AND BIT RATES**

### **6.1 Video MPEG-2 and MPEG-4 (H.264)**

Choice of operation is dependent on the characteristics and functionality of the type of TV receivers expected to be accessing the signal. Most Australian TV receivers are expected to be wide screen and HD capable with MPEG-2 and 4 decoding.

It's recommended that only widescreen picture sources (16:9 aspect ratio) are used, but if legacy standard 4:3 pictures are used then the aspect ratio setting in the encoder should be set to 4:3.

MPEG-4 typically provides equal picture quality at half the bit rate of MPEG-2 but in both cases, actual bit rate depends on several operating parameters

## FREE TV AUSTRALIA OPERATIONAL PRACTICE OP-71

Recommended Settings of DVB-T Transmitter/Modulator's Operating Parameters and Transport Stream SI for Use in Temporary Events or in TV distribution Systems

Issue 1  
December 2014  
Page 5 of 14

**Table 6.1: Typical Video Encoded Bit-rates**

Format	MPEG-2 SD	MPEG-2 HD*	MPEG-4 SD	MPEG-4 HD*	MPEG-4 HD
Horizontal x Vertical	720x576i	1920x1080i	720x576i	1280x720p	1920x1080i
Frame/Field rate	25 frames/ 50Fields/sec	25 frames/ 50Fields/sec	25 frames/ 50Fields/sec	50 frames/sec	25 frames/ 50Fields/sec
Aspect Ratio	16:9	16:9	16:9	16:9	16:9
Typical Bit rate	5 Mb/s	12 Mb/s	2.5 Mb/s	4 Mb/s	6 Mb/s

Note:

Suggested bit rates are basic (non-statistically multiplexed) from non-sophisticated single pass encoders – better encoders might deliver better quality pictures at lower bit-rates.

\* Australian TV broadcasters may use 1440x1080 (in 16:9) to improve video encoding quality for HD pictures.

### 6.2 Audio Encoding – MPEG-1 Layer2, AAC and AC-3

Australian broadcasters currently use MPEG-1 Layer2 encoding for stereo audio with SD video programs while HD programming may also include Dolby AC-3 audio encoding in either stereo or multichannel formats. Advanced Audio Coding (AAC) provides similar audio quality to MPEG-1 Layer 2 at much lower bit rates and that is now improved with High Efficiency AAC (HE-AAC) as used by Digital Audio Broadcasting DAB plus. TV receivers with MPEG-4 video decoding also provide for AAC and stereo HE-AAC decoding.

**Table 6.2: Typical Audio Encoded Bit-rates**

Parameter	MPEG-1 Layer2	AAC	HE-AAC	AC-3	AC-3 5.1 Channel Audio
Channels	2	2	2	2	5.1
Bit rate	256 kb/s	128kb/s	96kb/s	256kb/s	>384kb/s

## 7 MPEG TRANSPORT STREAM (TS) DATA RATE

Within an all-in-one DVB-T encoder–modulator the various bit streams of the encoded video and audio must be put into separate ‘packets’ of data each with an identifier header and then ‘multiplexed’ (MUXed) together into a single ‘Transport Stream’ (TS) along with other data (called tables) that tell a receiver what’s in the stream. That total stream is then fed to the COFDM modulator. The DVB-T COFDM system has a direct connection between the modulating parameters and the TS payload data rate. Acceptable maximum values of bit-rates for TSs are given in Annex B.

A more complete description of the structure of an MPEG-2 Transport Stream and DVB SI tables parameters is available (shortly) in the Free TV Engineering Guideline: “MPEG/DVB Tables and Descriptors usage in Australian television digital transmissions”.

## FREE TV AUSTRALIA OPERATIONAL PRACTICE OP-71

Recommended Settings of DVB-T Transmitter/Modulator's Operating Parameters and Transport Stream SI for Use in Temporary Events or in TV distribution Systems

Issue 1  
December 2014  
Page 6 of 14

The most commonly used parameters by Australian broadcasters for a 7 MHz channel are: 8K, 64QAM, Guard Interval of 1/16, and error correction Code Rate of 3/4. This gives a Transport Stream payload data capacity of exactly 23,052,768 bit/s.

However a modulator's total input stream must be below this data rate. The modulator adds padding (called bit stuffing), up to the full rate. If the input data does exceed this limit, an overflow occurs, data is lost and pixilation may be seen on a receiver's pictures.

In the less demanding environment of a closed cable system, the Guard Interval could be reduced to 1/32 as there should be virtually no echoes (ghosting). Also in the relatively low background noise level, error correction Code Rate may be reduced to 7/8. This will give the highest bit rate capacity of 27,709,893 bits/s for a 7 MHz channel width.

## 8 DVB-T MPEG SERVICE INFORMATION (PSI AND SI) TABLES

SI (and PSI) are 'tables' of data added to the transmitted transport stream and used by a receiver to determine what programs are carried and how to filter them out of the stream along with other useful information.

### 8.1 Network, Service and Transport Stream Identification

Australian broadcasters abide by the DVB Project group's register of all authorised DVB Identifiers to aid in the unique identification of DVB Broadcasts.

Locally generated digital services should not conflict with off-air digital services and avoid using already registered and allocated parameters such as 'original network ID' (ONID) and 'network ID' (NID). See Annex A.<sup>1</sup>

#### 8.1.1 DVB triplets

Each and every program service on DVB transmissions is uniquely identified by receivers by reading the following three identification values out of the transport stream tables:

- transport\_stream\_id,
- original\_network\_id
- service\_id)

This combination are known as a DVB Triplet. Their combination must remain a unique set and not confuse receivers by incorrectly identifying any program with an already assigned DVB Triplet set of values.

### 8.2 Logical Channel Number

See Annex A for a suggested value.

---

<sup>1</sup> (Refer also to Free TV's Australian Digital Terrestrial Television Broadcasting Service Information Register, Operational Practices OP40, 41, 44 and 45)

## FREE TV AUSTRALIA OPERATIONAL PRACTICE OP-71

Recommended Settings of DVB-T Transmitter/Modulator's Operating Parameters and Transport Stream SI for Use in Temporary Events or in TV distribution Systems

Issue 1  
December 2014  
Page 7 of 14

### 8.3 Time-Date and Time-Offset Tables (TDT and TOT)

If the modulator also includes a 'time and date table' and 'time offset table', it's strongly recommended these should be disabled unless they are there for a specific purpose.

The TDT and TOTs use UTC (GMT) time and a region offset value that may change with daylight saving. For example, the Australian state of NSW has an offset of +10 hours in AEST<sup>2</sup> and +11 in AEDT. (Refer to Free TV Operational Practice OP45).

In most cases, it would be difficult to set and regularly update these tables to be consistent with local off-air broadcasters' information and any difference will confuse receivers and PVRs when switching between channels.

### 8.4 Access to DVB-SI EIT p/f

If an event\_information\_table (EIT) is provided it should align to Section 4 of AS4599.1 – 2013. Refer also to Free TV OP44.

#### 8.4.1 Parental rating

If the DVB-T transport stream does not contain an EIT, then Parental rating cannot be carried. The parental\_rating\_descriptor is included in the EIT linked to a program event Clause 4.2.12 as specified in AS 4599.

## 9 RECOMMENDED SI PARAMETERS TO USE

### 9.1 Original\_network\_id

Original\_network\_id values are a scarce commodity, hence DVB usually register one unique value of original\_network\_id for each network operator in a country.

It is recommended the following are the non-registered or private\_temporary\_use range to be used for special events.

0xFF00 to 0xFFFF	Private_temporary_use (i.e. not subject to DVB Office registration)
------------------	---

#### As defined in:

EN 300 468 V1.8.1 §5.2.2;

TR 101 211 V1.8.1 §4.1.2

Refer - [http://www.dvbservices.com/identifiers/original\\_network\\_id](http://www.dvbservices.com/identifiers/original_network_id)

---

<sup>2</sup> Australian Eastern Standard Time

## 9.2 LOGICAL CHANNEL NUMBER

The Logical Channel Number (LCN) is carried in the Network Information Table (NIT) where it is linked to a program service's 'Service\_ID'.

If the LCN is able to be set, it should not be related to any LCNs used by the broadcast Networks. Reference is suggested to Free TV's Operational Practice OP41 – there's a selection of 'unallocated numbers in Table 3. 'Allocated Logical Channel Numbers'.

A recommended selection for trial transmissions are in the range of **450 to 499**.

If the program service is not logically numbered with an LCN, an Australian AS 4933 compliant receiver will assign the number automatically in the range of 350 to 399.. (Refer to Free TV Operational Practice OP41).

## 10 MODULATOR RF OUTPUT CHARACTERISTICS

### 10.1 Channel frequency limits

The modulator's RF output should be within its allocated RF spectrum mask as found in ETSI EN 300 744<sup>3</sup> and the Australian channel allocations are as listed in Annex C.

### 10.2 Carrier frequency and stability

Annex C provides 7 MHz digital channel centre frequencies that are 3.5 MHz above the lower edge of the nominated channel frequency.

The accuracy of the modulator's set RF output frequency should be within  $\pm 10$  kHz and a stability consistent with the phase noise requirements of consumer DVB-T receivers.

In a closed cable system carrier centre frequency offset should not be necessary and is not recommended. When offsets are used they are normally + or – 125 kHz in a 7 MHz system. Offsets are only normally applied due to the requirements of some combining filters in terrestrial broadcast transmissions.

### 10.3 Out of BAND and spurious EMISSION

When an output Digital TV channel is positioned adjacent to another Digital TV channel, any spurious including intermodulation, harmonics, and local oscillator related products plus other unwanted products derived from the modulator should—

- (a) at the edge of channel be attenuated at least 40 dB below the channel power;
- (b) sloping to 7 MHz away, be attenuated at least 60 dB below the channel power; and
- (c) sloping to 14 MHz away and beyond, be attenuated at least 70 dB below the channel power.

---

<sup>3</sup> For a 7 MHz channel



## FREE TV AUSTRALIA OPERATIONAL PRACTICE OP-71

Recommended Settings of DVB-T Transmitter/Modulator's Operating Parameters and Transport Stream SI for Use in Temporary Events or in TV distribution Systems

Issue 1  
December 2014  
Page 9 of 14

---

The measurement shall be conducted as a relative spectral density with a resolution bandwidth of 50 kHz to 230 kHz.

If the output Digital TV channel is positioned adjacent to an Analog TV channel the spurious derived from the modulator shall—

- (a) at the edge of channel be attenuated at least 60 dB below the channel power; and
- (b) sloping to 14 MHz away and beyond, be attenuated at least 70 dB below the channel power.

Reference should be made to the manufacturer's set-up instructions.

### 11 AUDIO LEVELS & LOUDNESS SPECIFICATIONS FOR PROGRAM CONTENT VIA SERVICES

Program content distributed via these modulator units intended to be viewed/listened to on standard domestic TVs should have audio levels set to be consistent with program content that is provided via the regular over-the-air broadcasts.

#### 11.1 Audio Specifications:

- Audio Reference level = -20dBFs
- Loudness level = -24LKFs
- Maximum True Peak = -2dBTP.

### 12 TERMINOLOGY AND ACRONYMS

Within this OP the following definitions are understood.

Australian Free to Air Television broadcasters (Broadcasters) – includes national, commercial and community television broadcasters

DVB-T Pilot and TPS (Transmission Parameters Signalling) use some of the carriers in a modulation mode more easily received to help the receiver lock to the digital signal. This is further helped by the TPS which sends the parameters of the transmitted signal.

2K & 8K Modulation: Orthogonal Frequency Division spreads the transmitted data over many separate RF carriers. DVB-T can operate in either of two modes known as 2K or 8K mode. The 2k mode has 1705 RF carriers, while 8k mode has 6817 carriers.

8K transmits the data on each carrier at a slower rate (1/4 of 2K) and is better for over-the-air environments where reception echoes (ghosting) may occur. Increasing the number of carriers does not modify the payload bit rate, which remains constant.

Guard interval: The width can be 1/32, 1/16, 1/8, or 1/4 of the symbol time period. The introduced delay allows most of the reflected signals (ghosts) to arrive before the carriers change to their next positions for the next symbol period.

ERP: Effective Radiated Power (as applies to terrestrial broadcast transmissions as authorised by the ACMA — This is the maximum power radiated in a given direction as

## FREE TV AUSTRALIA OPERATIONAL PRACTICE OP-71

Recommended Settings of DVB-T Transmitter/Modulator's Operating Parameters and Transport Stream SI for Use in Temporary Events or in TV distribution Systems

Issue 1  
December 2014  
Page 10 of 14

determined by the radiation pattern and gain of the transmit antenna with a given transmitter output power (less the loss in the feeder cable).

### 13 REFERENCES

	Reference Document	Title
[1]	AS 4599.1-2010	Digital television – Terrestrial broadcasting – Characteristics of digital terrestrial television transmissions
[2]	AS 4933	Digital television – Requirements for Receivers Part 1: VHF/UHF DVB-T television broadcasts
[3]	Free TV	Australian Digital Terrestrial Television Broadcasting Service Information Register
[4]	Free TV OP 40	Allocation of DVB Service Information Codes for Australia
[5]	Free TV OP 41	Logical Channel Descriptor and Allocation of Logical Channel Numbers
[6]	Free TV OP 45	Application of Time Related Tables in Australian DVB-T Systems
[7]	ETSI EN 300 468	Specification for Service Information (SI) in DVB systems
[8]	ETSI 101 211	Guidelines on implementation and usage of Service Information (SI)
[9]	ETSI TS 101 162	Allocation of identifiers and codes for Digital Video Broadcasting (DVB) systems

Free TV Australia references are available from [www.freetv.com.au/](http://www.freetv.com.au/)

Listings of Australian digital TV channels, transmission sites, market areas and allocation of channel frequencies to Australian terrestrial broadcasters may be found at:

<http://www.acma.gov.au/Industry/Broadcast/Television/List-of-TV-broadcasters/digital-tv-channels-television-acma>

# FREE TV AUSTRALIA OPERATIONAL PRACTICE OP-71

Recommended Settings of DVB-T Transmitter/Modulator's Operating Parameters and Transport Stream SI for Use in Temporary Events or in TV distribution Systems

Issue 1  
December 2014  
Page 11 of 14

## ANNEX A.

### Summary of Recommended Settings

Initial Requirements:

Operating Parameter	MATV (in-house) SYSTEM	TERRESTRIAL SHORT EVENT
<b>RF Channel Frequency</b>	Choose from Annex C but avoid use of local off-air channels	As authorised by the ACMA
<b>Bandwidth</b>	7 MHz	7 MHz
<b>Power Level</b>	As required – typically -20 dBm	ERP and coverage pattern as authorised by the ACMA

Basic Settings: The basic operating parameters are usually set in a computer screen (e.g. typically a 'browser' such as Windows Explorer/Chrome or Safari).

Initial determining requirements take into account there may be different conditions for an external terrestrial short event broadcast depending on whether a single or multiple programs are carried.

Requirement	MATV (in-house) SYSTEMS	TERRESTRIAL SHORT EVENT	TERRESTRIAL SHORT EVENT
<b>Number of programs carried</b>	1 to 4 depending on whether SD and/or HD and either MPEG-2 or MPEG-4 (H.264) encoding	for a single program	2 or more programs carried

Suggested Operating Parameters

Operating Parameter	MATV (in-house) SYSTEM	Short Event – Single Program	Short Event – Multi Programs
<b>COFDM Mode</b>	8K	8K	8K
<b>Constellation</b>	64QAM	QPSK	16QAM or 64QAM
<b>Hierarchical</b>	Non-Hierarchical	Non-Hierarchical	Non-Hierarchical
<b>Code Rate</b>	5/6	2/3	2/3 or 3/4
<b>Guard Interval</b>	1/32	1/8	1/8 or 1/16
<b>Available bit rate (from Annex 2)</b>	26.3 Mb/s	6.4 Mb/s	12.9 or 23 Mb/s
<b>Suggested Video</b>	SD & HD MPEG 2 & 4	1xSD MPEG-2 or 1xHD MPEG-4	1xHD + 2xSD MPEG-4 in 12.9 Mb/s or 1xHD + 2xSD MPEG-2 in 23Mb/s

## FREE TV AUSTRALIA OPERATIONAL PRACTICE OP-71

Recommended Settings of DVB-T Transmitter/Modulator's Operating Parameters and Transport Stream SI for Use in Temporary Events or in TV distribution Systems

Issue 1  
December 2014  
Page 12 of 14

### SI TABLE VALUES

<b>TABLES</b>	<b>Recommended value</b>	<b>Application</b>	<b>Needed</b>
<b>PAT</b>	PID is always 0x0000	<b>Needs TSID, ONID</b>	Y
<b>PMT(s)</b>	A & V PIDs Usually assigned by unit	<b>Tells receiver where A &amp; V are</b>	Y
<b>NIT</b>	PID is always 0x0010 (16dec) for DVB	<b>Contains LCN value</b>	U
<b>SDT</b>	PID is always 0x0011	<b>List of program services</b>	U
<b>EIT</b>	PID is always 0x0012	<b>Program guide</b>	N
<b>TDT &amp;TOT</b>	PID is always 0x0014	<b>Time &amp; Date</b>	N
<b>Network Name</b>	The Network Name (text) is chosen by the operator (Tag value is always 0x40)	<b>In the Network Information and other Tables</b>	P
<b>Service Name(s)</b>	The operator usually chooses the name for each Service (program) (text)	<b>In the Network Information and other Tables</b>	P
<b>TSID</b>	The Transport Stream ID is a number Tag value always is 0x67	<b>In the Network Information Table</b>	Y
<b>ONID</b>	Value which should be used is 0xFF00	<b>In the Network Information and other Tables</b>	Y
<b>NID</b>	Range which should be used is 0x32E1 - 0x32E3	<b>In the Network Information and other Tables</b>	Y
<b>SID</b>	Service ID is a number that in some units might be chosen by the operator or automatically assigned by the MUX (Tag value is always 0x71)	<b>In the Service Description and other Tables</b>	Y
<b>LCN</b>	Range which should be used is 450 to 499	<b>In the Network Information Table</b>	U, P

Needed: Y – yes; N – no; U – usually; P – value provided by operator

# FREE TV AUSTRALIA OPERATIONAL PRACTICE OP-71

Recommended Settings of DVB-T Transmitter/Modulator's Operating Parameters and Transport Stream SI for Use in Temporary Events or in TV distribution Systems

Issue 1  
December 2014  
Page 13 of 14

## ANNEX B.

### DVB-T BITRATE (Mbits/s) in a 7 MHz CHANNEL

#### For Combinations of Guard Interval, Constellation and Code Rate

Constellation Modulation	Code rate (FEC)	For Guard interval (Duration for 8K carriers) (2)			
		1/4 (256 $\mu$ s)	1/8 (128 $\mu$ s)	1/16 (64 $\mu$ s)	1/32 (32 $\mu$ s)
QPSK	1/2	4.354412	4.838235	5.122837	5.278075
	2/3	5.805882	<b>6.450980 (3)</b>	6.830450	7.037433
	3/4	6.531618	7.257353	7.684256	7.917112
	5/6	7.257353	8.063725	8.538062	8.796791
	7/8	7.620221	8.456912	8.964965	9.236631
16-QAM	1/2	8.708824	9.676471	10.245675	10.556150
	2/3	11.611765	12.901961	13.660900	14.074866
	3/4	13.063235	14.514706	15.368512	15.834225
	5/6	14.514706	16.127451	17.076125	17.593583
	7/8	15.240441	16.933824	17.929931	18.473262
64-QAM	1/2	13.063235	14.514706	15.368512	15.834225
	2/3	17.417647	19.352941	20.491349	21.112299
	3/4	19.594853	21.772059	<b>23.052768 (1)</b>	23.751337
	5/6	21.772059	24.191176	25.614187	<b>26.390374 (4)</b>
	7/8	22.860662	25.400735	26.894896	27.709893

#### NOTES:

1. Rate used by most Australian free-to-air terrestrial 8K, 64QAM, 1/16 GI, 3/4 CR transmissions;
2. Longer guard Intervals reduce the effect of signal echoes (ghosting) encountered in terrestrial transmission but ghosting should be absent in a well-designed MATV system;
3. Suggested operating point for a low-powered terrestrial (special event) transmission carrying a H.264 encoded HD video program.
4. Suggested operating point for an added DVB-T signal carrying several programs in an MATV system
5. The input transport stream to the COFDM modulator should be slightly less than the maximum figure to avoid occasional overrun that causes picture pixilation and breakup;
6. These bit-rate figures are for 7MHz channels.

# FREE TV AUSTRALIA OPERATIONAL PRACTICE OP-71

Recommended Settings of DVB-T Transmitter/Modulator's Operating Parameters and Transport Stream SI for Use in Temporary Events or in TV distribution Systems

Issue 1  
December 2014  
Page 14 of 14

## ANNEX C.

### Australian Broadcast and Non-Broadcast RF Channel Frequencies

Australian 7 MHz Channel Number	7 MHz Channel Frequency Limits (MHz)	7 MHz Digital Channel Centre Freq (MHz)	Channel Block	Australian 7 MHz Channel Number	7 MHz Channel Frequency Limits (MHz)	7 MHz Digital Channel Centre Freq (MHz)	Channel Block
<b>VHF Band III CHANNELS</b>							
6	174 – 181	177.5	A	44	638 – 645	641.5	D
7	181 – 188	184.5	A	45	645 – 652	648.5	D
8	188 – 195	191.5	A	46	652 – 659	655.5	E
9	195 – 202	198.5	(Note 1)	47	659 – 666	662.5	E
9A	202 – 209	205.5	(Note 1)	48	666 – 673	669.5	E
10	209 – 216	212.5	A	49	673 – 680	676.5	E
11	216 – 223	219.5	A	50	680 – 687	683.5	E
12	223 – 230	226.5	A	51	687 – 694	690.500	E
<b>UHF BAND IV and V CHANNELS</b>				<b>NON BROADCAST CHANNELS</b>			
27	519 – 526	522.5	(Note 2)	52	694 – 701	697.500	NonB'cast
28	526 – 533	529.5	B	53	701 – 708	704.500	NonB'cast
29	533 – 540	536.5	B	54	708 – 715	711.500	NonB'cast
30	540 – 547	543.5	B	55	715 – 722	718.500	NonB'cast
31	547 – 554	550.5	B	56	722 – 729	725.500	NonB'cast
32	554 – 561	557.5	B	57	729 – 736	732.500	NonB'cast
33	561 – 568	564.5	B	58	736 – 743	739.500	NonB'cast
34	568 – 575	571.5	C	59	743 – 750	746.500	NonB'cast
35	575 – 582	578.5	C	60	750 – 757	753.500	NonB'cast
36	582 – 589	585.5	C	61	757 – 764	760.500	NonB'cast
37	589 – 596	592.5	C	62	764 – 771	767.500	NonB'cast
38	596 – 603	599.5	C	63	771 – 778	774.500	NonB'cast
39	603 – 610	606.5	C	64	778 – 785	781.500	NonB'cast
40	610 – 617	613.5	D	65	785 – 792	788.500	NonB'cast
41	617 – 624	620.5	D	66	792 – 799	795.500	NonB'cast
42	624 – 631	627.5	D	67	799 – 806	802.500	NonB'cast
43	631 – 638	634.5	D	68	806 – 813	809.500	NonB'cast
				69	813 – 820	816.500	NonB'cast

#### NOTES:

- (1) Usually intended for DAB Plus radio transmissions.
- (2) Availability of Channel 27 for terrestrial broadcast not confirmed.
- (3) Radio frequency channel allocations in each license area in Australia may be found at: <http://www.acma.gov.au/Industry/Broadcast/Television/List-of-TV-broadcasters/digital-tv-channels-television-acma>